



# 1-800-My1Stop

**11" x 17" Calendar (half fold)  
folds to 11" x 8.5"**

Save each page spread or side as a separate eps file.  
(ex: 28 page calendar equals 14 eps files)

Please import template files at 300 DPI.

If you require printing to the edge after trimming, please ensure that your artwork extends into the gray bleed area. Anything in the gray shaded area will be trimmed off.

Text should be a minimum of 1/8" inside the cut line on each side.  
This is represented as the blue safety box.

**Delete This Layer Before Submitting Artwork.**

fold

fold

### Proper Page Orientation

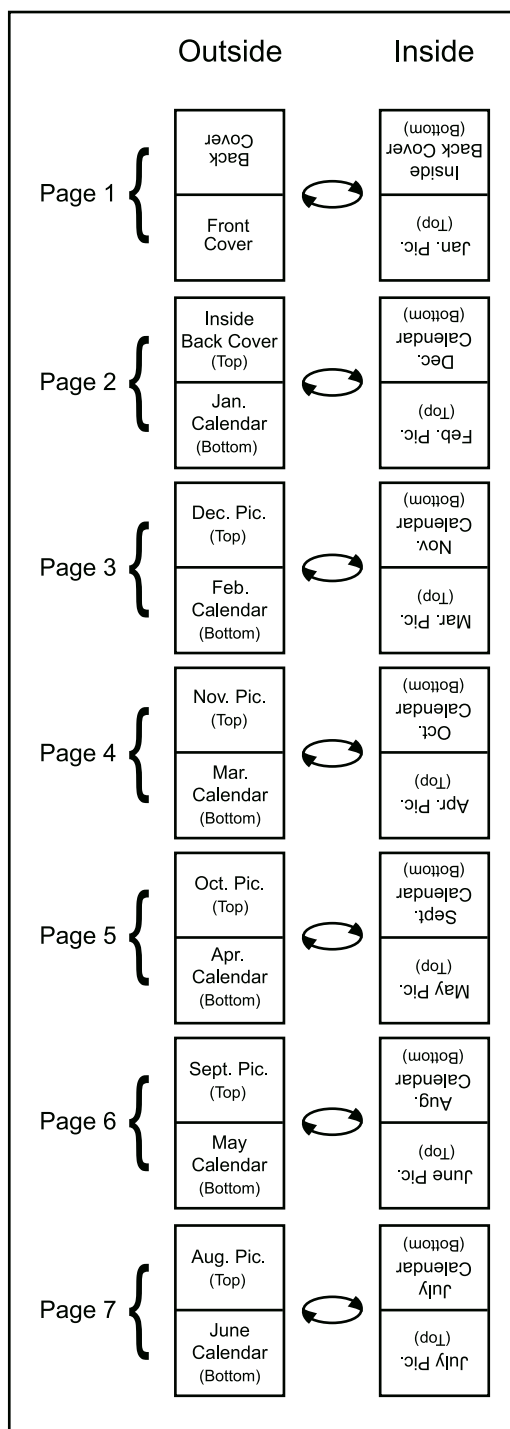

bleed

cut line

safety